

A:  X28

B:  X28

C:  X10

(1)

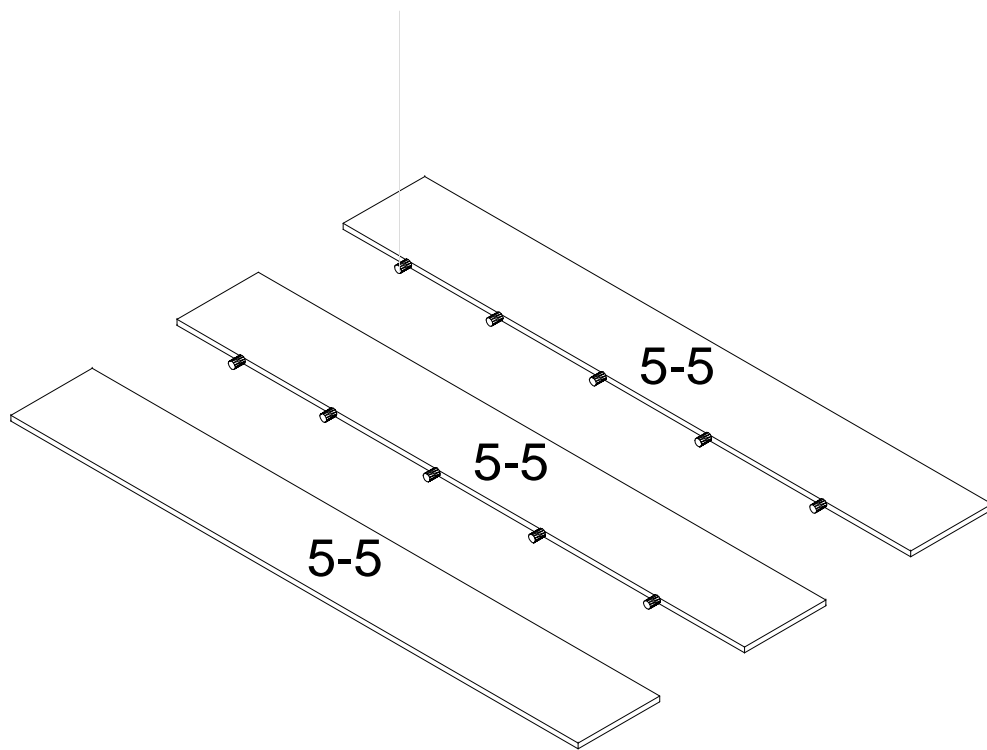

Step 1: Use C to connect 5-5

(2)

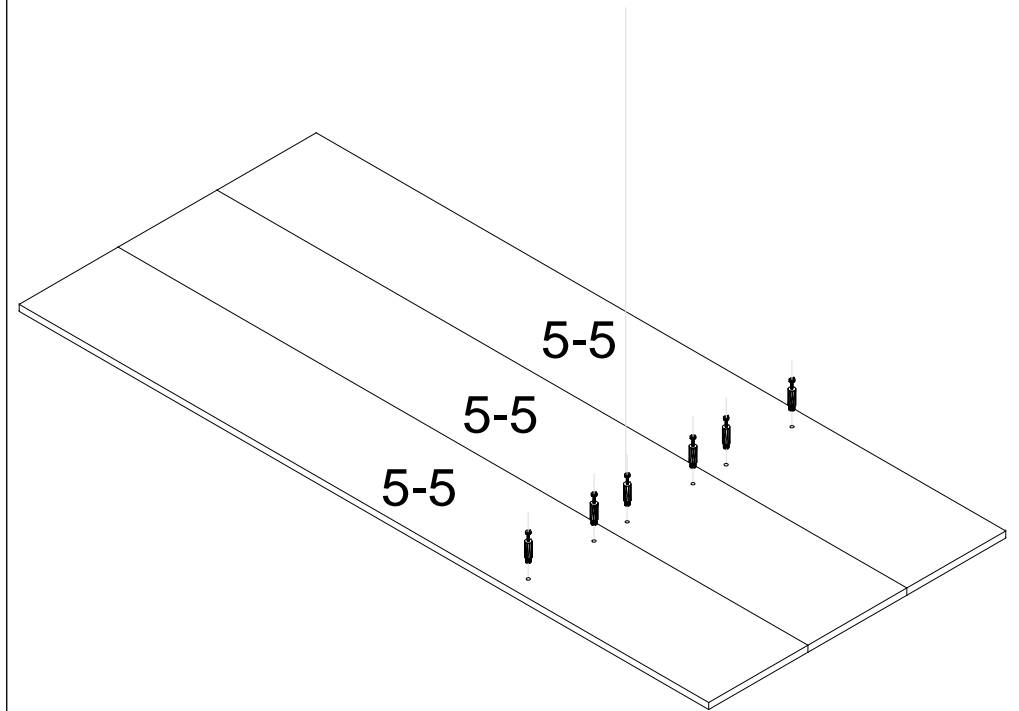

Step 2: Screw A into place

(3)

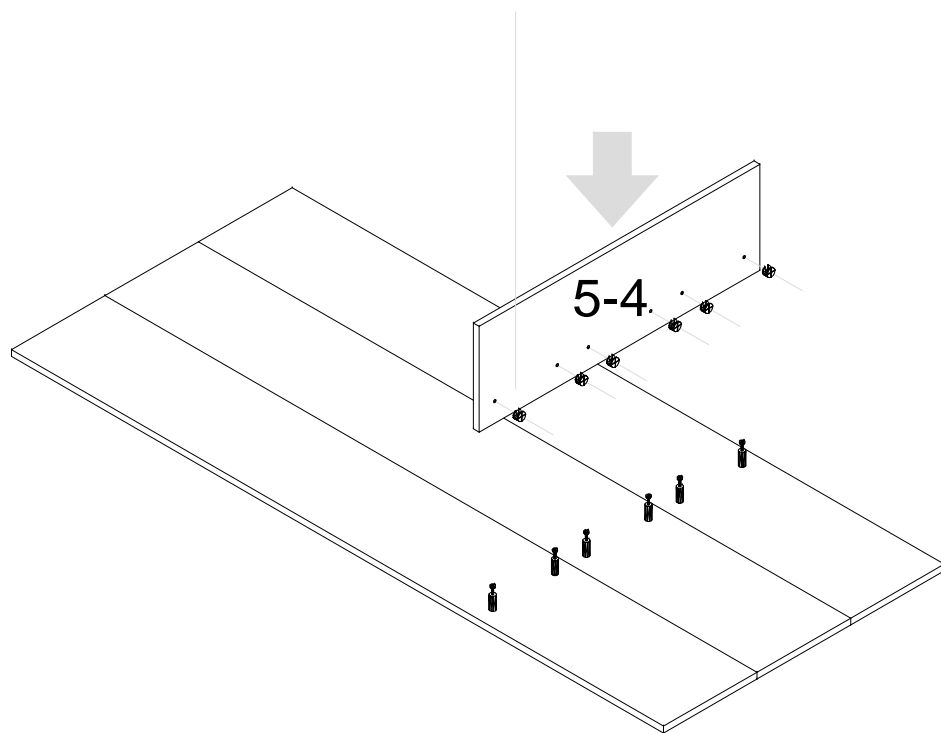

Step 3: Use B to connect 5-4

(4)

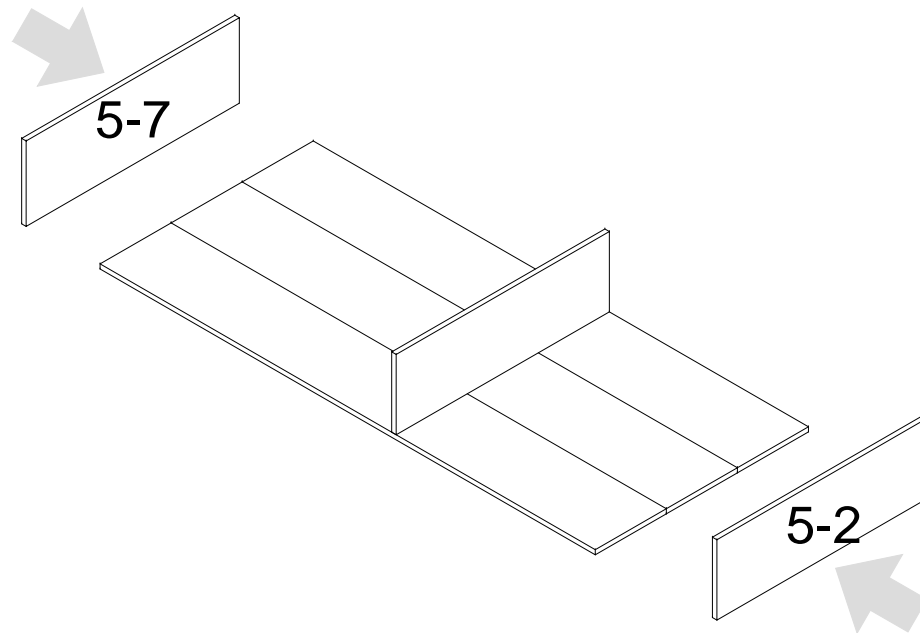

Step 4: Move 1 and 2 to the appropriate position

(5)

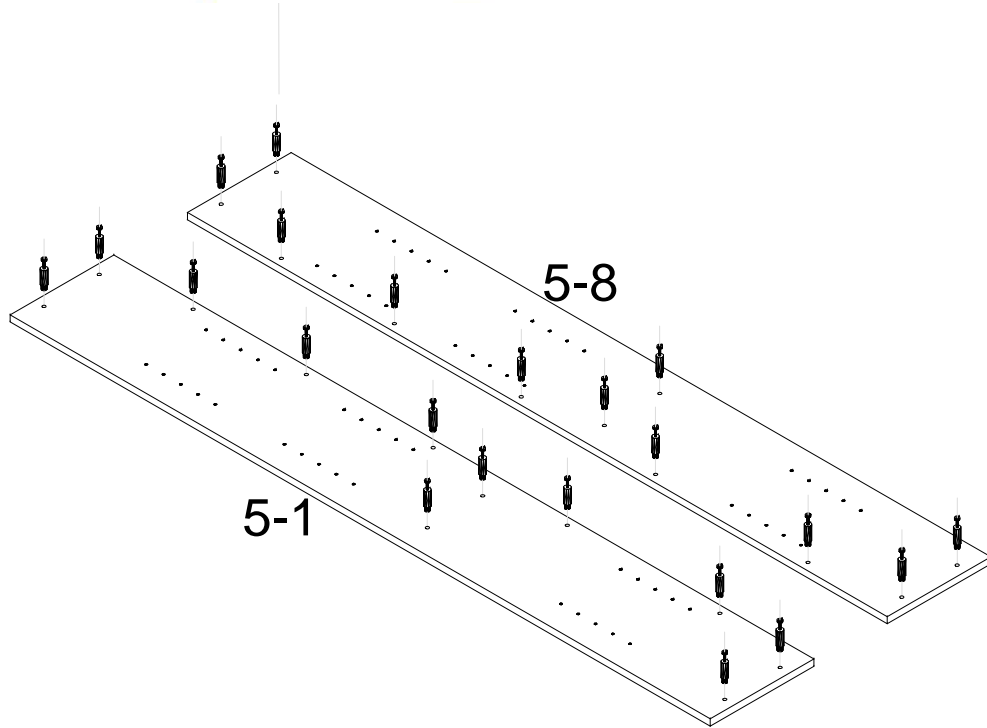

Step 5: Screw A into place

(6)

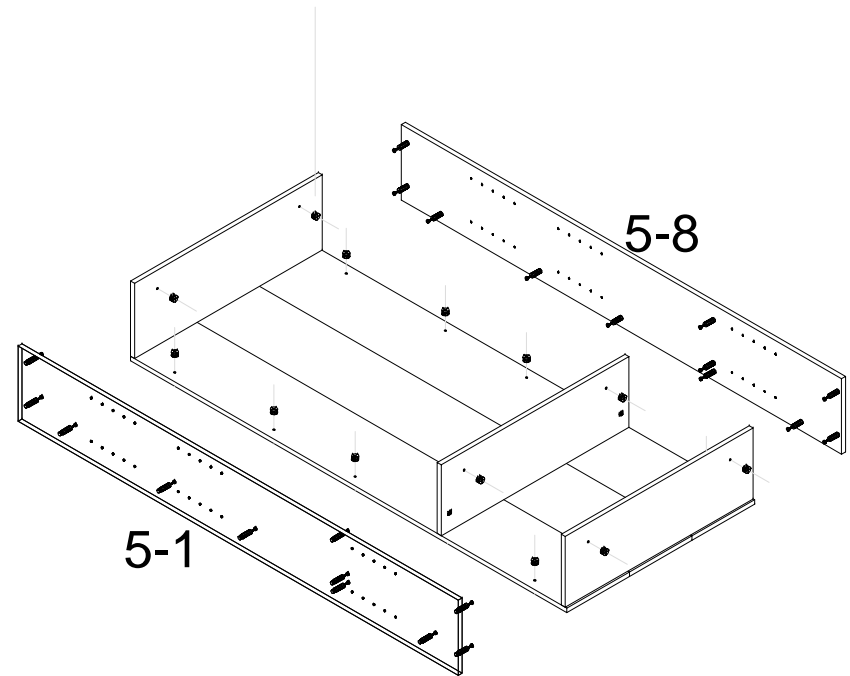

Step 6: Use B to connect related parts

(7)

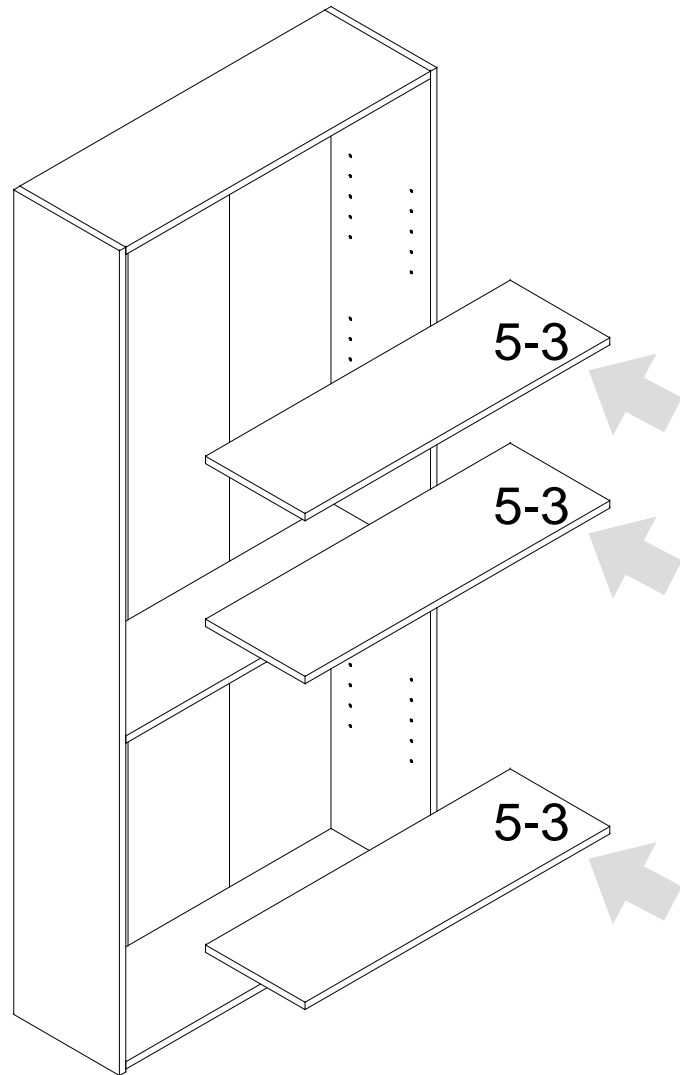

Step 7: Put 5-3 in place

(8)

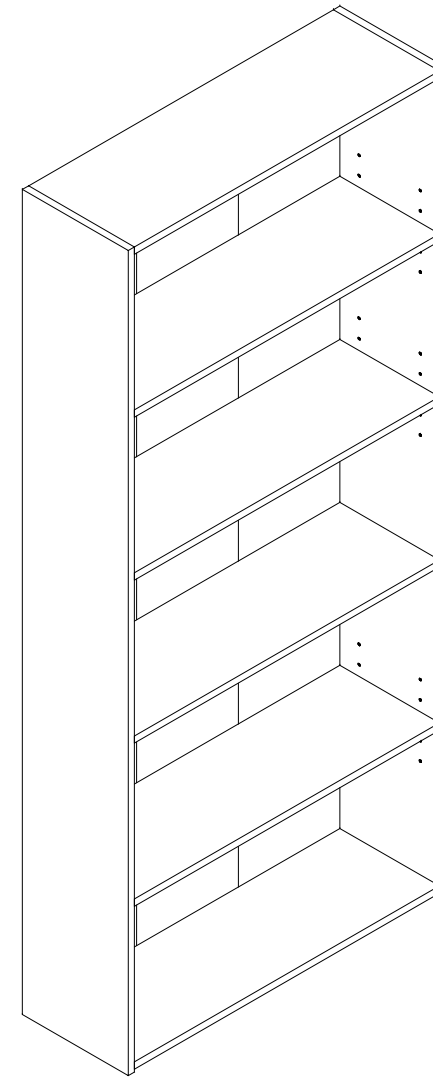

Step 8: finish installation